

# TEE Straight

Extended ends for orbital welding

DT-4.1.2-1 (DT-g)

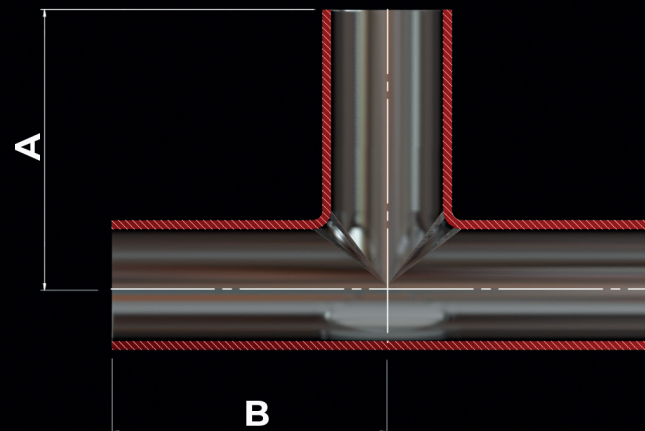

Ø (Diameter)	OD	ID	THK	A	B
1/4"	6,35	4,57	0,89	44,5	44,5
3/8"	9,53	7,75	0,89	44,5	44,5
1/2"	12,7	9,4	1,65	47,6	47,6
3/4"	19,05	15,75	1,65	50,8	50,8
1"	25,4	22,1	1,65	54,0	54,0
1.1/2"	38,1	34,8	1,65	60,3	60,3
2"	50,8	47,5	1,65	73,0	73,0
2.1/2"	63,5	60,2	1,65	79,4	79,4
3"	76,2	72,9	1,65	85,7	85,7
4"	101,6	97,38	2,11	104,8	104,8
6"	152,4	146,86	2,77	142,9	142,9

## Manufacture Material

ASTM A270 S2 UNS  
S31603 (316L)

## Finishing

### Internal

**SF1:** Ra < 0,50 µm (20 µin)  
Mechanical Polishing

**SF4:** Ra < 0,375 µm (15 µin)  
Electropolishing

### External

Ra 0,80 µm (32 µin)

Measurements in mm - Dimensions according to ASME BPE standard (Table DT-3-1)

**X-STEEL**